



## Genie® Joule-Thomson Regulator™ Installation & Operation Instructions



### Manufacturing Contact Information

**A+ Corporation, LLC** *Call for expert product application assistance:*  
41041 Black Bayou Rd. Phone: (225)-644-5255 Website: [www.geniefilters.com](http://www.geniefilters.com)  
Gonzales, LA 70737 Fax: (225)-644-3975 E-mail: [sales@geniefilters.com](mailto:sales@geniefilters.com)

### Safety Warnings

- ⚠ Failure to abide by any of the safety warnings will result in release of fluid at full pipeline pressure and could result in serious injury or death.
  - ▶ Do not exceed any equipment pressure ratings.
  - ▶ Not designed for external fire.
  - ▶ Prior to use in a system, a properly sized relief device is to be installed which limits the use to 110% of the MAWP.
  - ▶ **Do not use the regulator as a shut off device.**

## Technical Specifications

### Technical Specifications

<b>Operating pressure range</b>	300 psig (20.7 barg) to 6,000 psig (413.7 barg)
<b>Temperature range</b>	-40°F (-40°C) to 300°F (149°C) * Actual limit depends on sealing material chosen. Refer to Temperature Range Comparison Chart.
<b>Port sizes</b>	1/4" female NPT
<b>Outlet pressure range</b>	0-10 psig (0-0.7 barg), 0-25 psig (0-1.7 barg) 0-50 psig (0-3.4 barg), 0-100 psig (0-6.9 barg), 0-250 psig (0-17.2 barg), 0-500 psig (34.5 barg)
<b>C<sub>v</sub> coefficient</b>	0.009
<b>Wetted materials</b>	Machined parts: 316/316L stainless steel / NACE compliant All other metal parts: stainless steel / NACE compliant Regulator Seat material: PFA Seals: User defined

## Dimensions

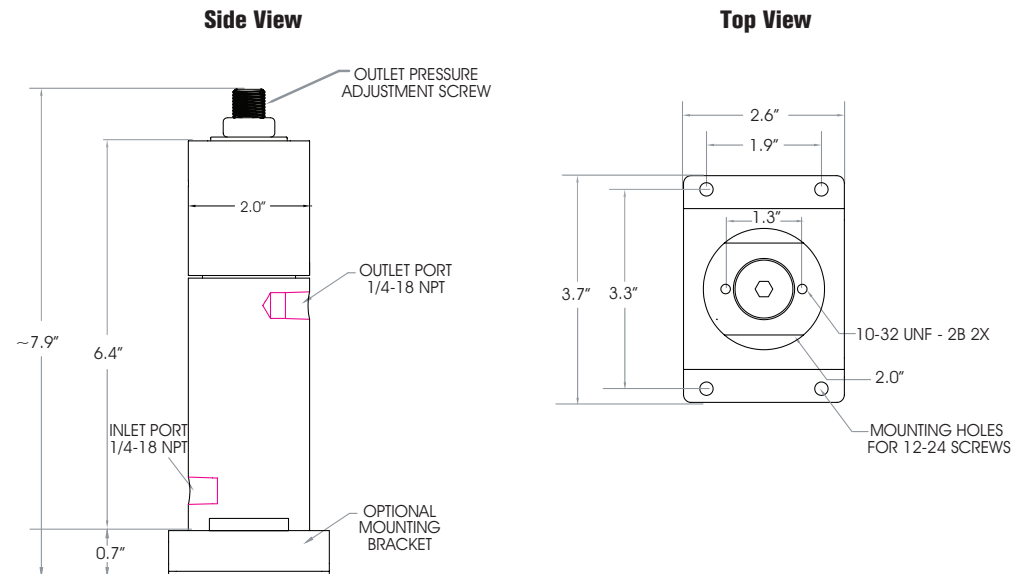

## Installation Instructions

### Step 1. Depressurize the system

- ▶ Valve off the sample flow prior to installation of the Genie® Joule Thomson Regulator.™

### Step 2. Connect the Genie® Joule Thomson Pressure Regulator

- ▶ The Genie inlet and outlet ports are labeled. Connect tubing from the sample stream to the Genie Inlet port (must have a minimum inlet pressure of 300 PSIG, consult factory for applications under this.). Connect tubing from the Genie Outlet port to the next device in the sample system.

### Step 3. Adjust pressure

- ▶ At this point the sample pressure can be adjusted to the desired value. To raise the outlet pressure, turn the pressure adjustment screw clockwise. To lower the outlet pressure, turn the pressure adjustment screw counterclockwise while gas is flowing through the regulator.
- ▶ To allow sample flow, slowly open external valving.
- ▶ At high supply pressure, a sudden change may be observed on the downstream pressure gauge as the valve stem moves away from the seat. Slight re-adjustments may be necessary until the pressure and flow have equilibrated.
- ▶ Tighten the pressure adjustment screw lock nut firmly against the washer to prevent unintended changes in pressure adjustment.

## Model Numbering & Additional Part Numbers

### Model Numbering & Additional Part Numbers

Your model number is determined by your specific needs. Choose options below.

<b>Sealing material</b>	0 = Fluoroelastomer	JW = RGD Resistant HNBR	<i>(other materials available upon request)</i>			
<b>Outlet pressure range (psig)</b>	0 = 0-25	1 = 0-50	2 = 0-100	3 = 0-250	4 = 0-500	9 = 0-10

#### How to build the model number:

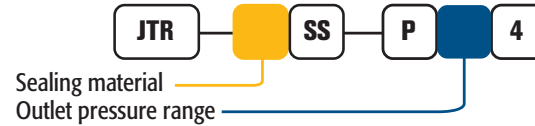

#### How to build the seal replacement model number:



#### Spare Parts & Accessories (sold separately)

- Optional Mounting Bracket - Part # JTR-509SS
- Kozy Insulated Cover - Part # KZ-10-L
- Inlet filter replacement - Part # JTR-5FSS
- Manifold with pressure gauge, ball valve, & relief valve - for ordering information, refer to the Genie® Probe Regulator Accessory Manifold product sheet